

SKIPPER

Double Bottom Sea Valve

DB-100-SB

Operation and Installation Manual

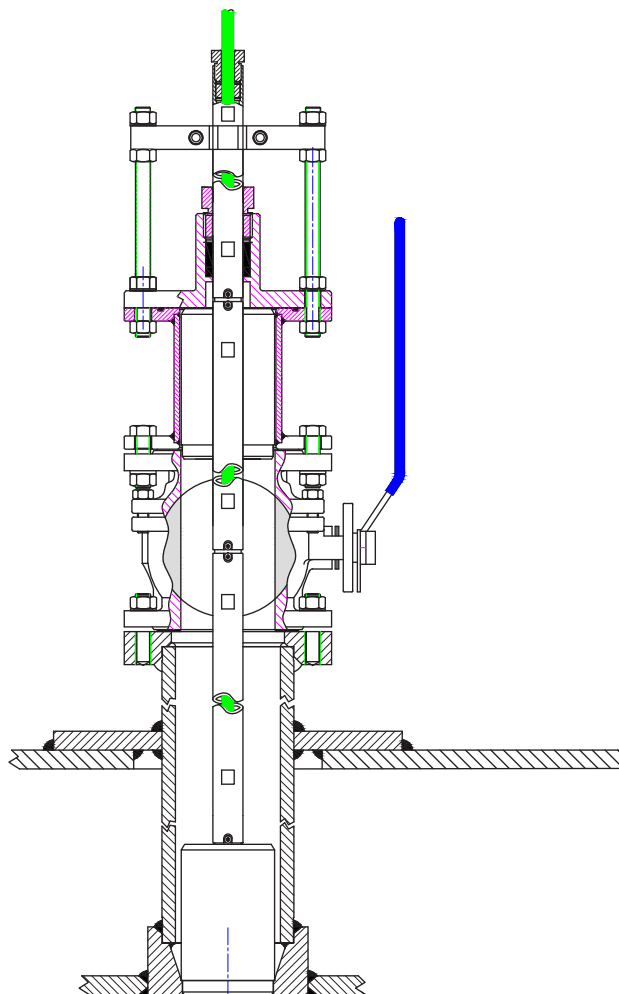

SKIPPER Electronics AS
Enebakkveien 150
P. O. Box 151, Manglerud
0612 Oslo,
Norway

www.skipper.no
E-mail: support@skipper.no
Telephone: +47 23 30 22 70
Co. reg. no: NO-965378847-MVA

Document no: **DM-BDB100-SB**
Rev 1003A
Date: 2019-02-12

Weitergabe sowie vervielfältigung dieser unterlage, verwertung und mitteilung ihres inhaltes nicht gestattet, soweit nicht ausdrücklich zugestanden. Zuwiderhandlungen verpflichten zu schadenersatz.

Toute communication ou reproduction de ce document, toute exploitation ou communication de ou son contenu sont interdites, sauf autorisation expresse. Tout manquement à cette règle est illicite et expose son auteur au versement de dommages et intérêts.

Copying of this document, and giving it to others and the use or communication of contents thereof, are forbidden without express authority. Offenders are liable to the payment of damages.

Sin nuestra expresa autorización, queda terminantemente prohibida la reproducción total o parcial de este documento, así como su uso indebido y/o su exhibición o comunicación a terceros. De los infractores se exigirá el correspondiente resarcimiento de daños y perjuicios.

Contents

1. Installation.....	4
2. Space considerations.....	6
3. Intermediate Tube	7
4. Blanking plate	8
5. Welding the bottom flange	9
6. Sea Valve Assembly.....	11
7. Assembling of first extension tube and sensor	12
8. Sensor installation.....	13
9. Clamp Unit mounting	14
10. Extension tube mounting order.....	15
11. Final assembly.....	17
12. Sensor removal.....	18
13. Re-installation.....	19
14. DB-100 Sensors	20
15. 100 mm Double Bottom Ball Valve.....	21

SKIPPER DB (Double Bottom) Sea Valve 100 mm

1. Installation

The SKIPPER DB Sea Valve 100 mm is used for installation of SKIPPER speed log sensors and echo sounder transducers fitted with adaptor for XB-100-XX.

Caution!

Be aware that the Sea Valve contains high precision parts and therefore proper handling when mounting is essential for the final result.

When handling the Sea Valve, all lifting devices must be attached on the outside of the valve. It is very important to not insert any chains, wire, rope or any other device into the valve chamber. This to avoid damaging and any kind of pollution of the Sea Valve.

Caution must be taken when mounting seavalves that all parts are aligned correctly, and that the inside is clean. DO NOT use liquid sealants, and DO NOT paint the inside of a valve.

The SKIPPER DB Sea Valve 100 mm is delivered partly assembled for transport. The parts necessary for final assembly will be found packed in a box delivered with the Sea Valve. First of all, it must be decided where the Sea Valve should be installed. Normally, this will be in the fore part of the ship, in the centerline, or as close to the centerline as possible. Optimal system operation is achieved by fitting the transducer/sensor as deep as possible on the hull.

- The active surface of the sensor must be installed with front face a maximum of +/-1 degree to the ships horizontal plane. (Speed Logs).
- The active surface of the transducer must be installed with front face a maximum of +/-7 degree to the ships horizontal plane. (Echo Sounder).

Do not mount transducers close to the bow thruster propeller outlets, or aft of other hull installations (outlets, vents or other protruding details) who may create aeration or turbulence.

It is necessary to select a part of the hull that is submerged and free from turbulence and aeration under all load and speed conditions, and to avoid positions where air is trapped in heavy weather.

If a flat, horizontal section is not available for transducer fitting, the shipyard must construct a suitable bed. Welding seams in this area should be smoothed and rounded off, in order not to create turbulence or aeration at speed.

Protect the active element of the transducer/sensors during transport and installation, and **do not paint the surface.**

The Sea Valve should be placed in a service accessible place, large enough for installation and disassembly of the sensor unit. See drawing: "Space considerations".

Important

”Sensors for Speed Log and Echo Sounder are delivered with a fixed cable. Needed attention must be taken to allow easy replacement/pulling of new cable during maintenance”.

SKIPPER Electronics AS can help recommend installation positions if GA-drawings (General arrangements), lines drawings and frame drawings are made available for study.

Condition.

The welding to hull structures and structural support of the items may be subject to separate approval by classification societies for each installation on board a ship.

Note: All “Item (X)” references on the following pages, can be found on the drawing “100 mm Double Bottom Ball Valve” .

2. Space considerations

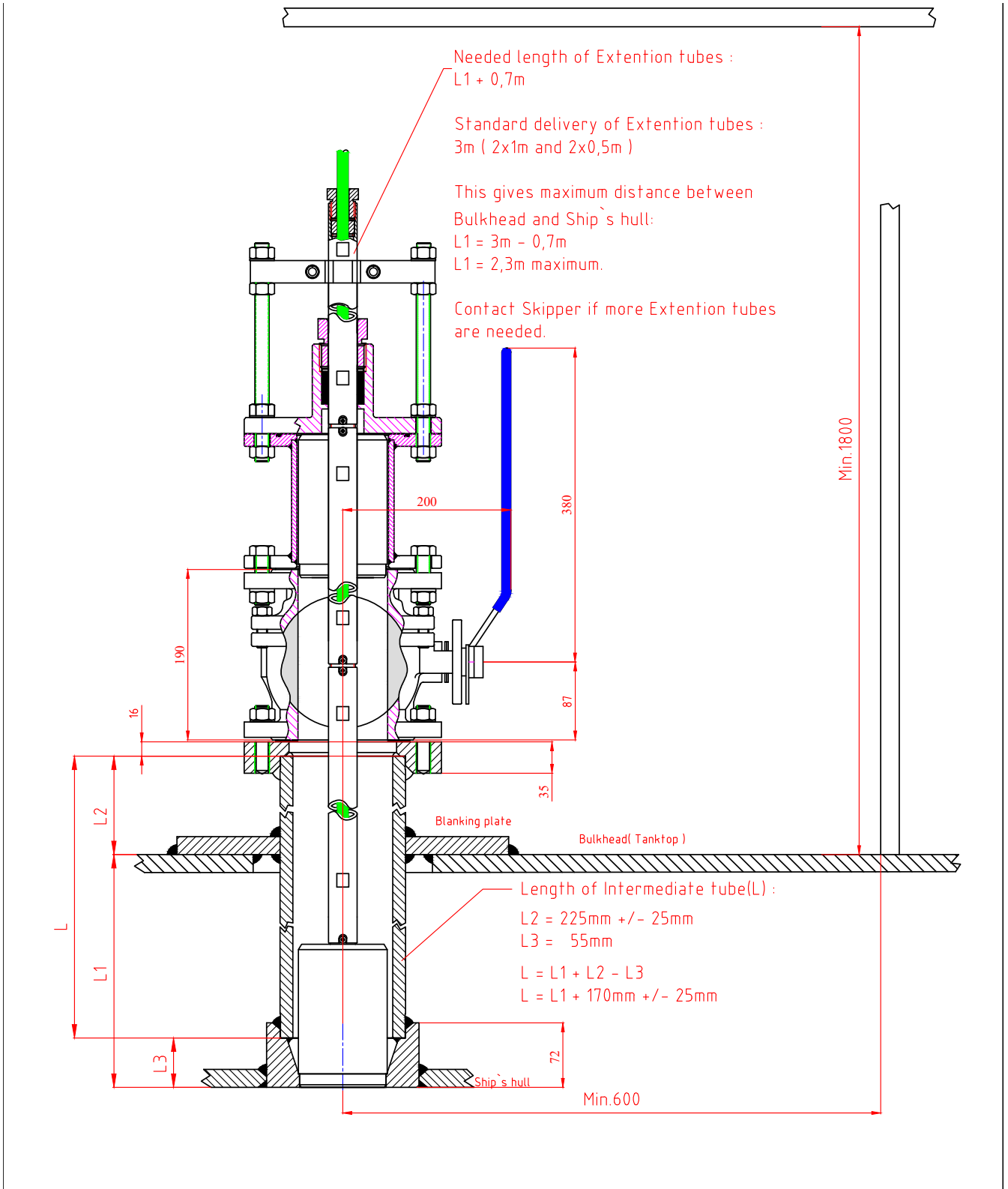

The Sea Valve should be placed in a service accessible place large enough for installation and disassembly of the transducer/sensor unit.

3. Intermediate Tube

*** Yard supply**

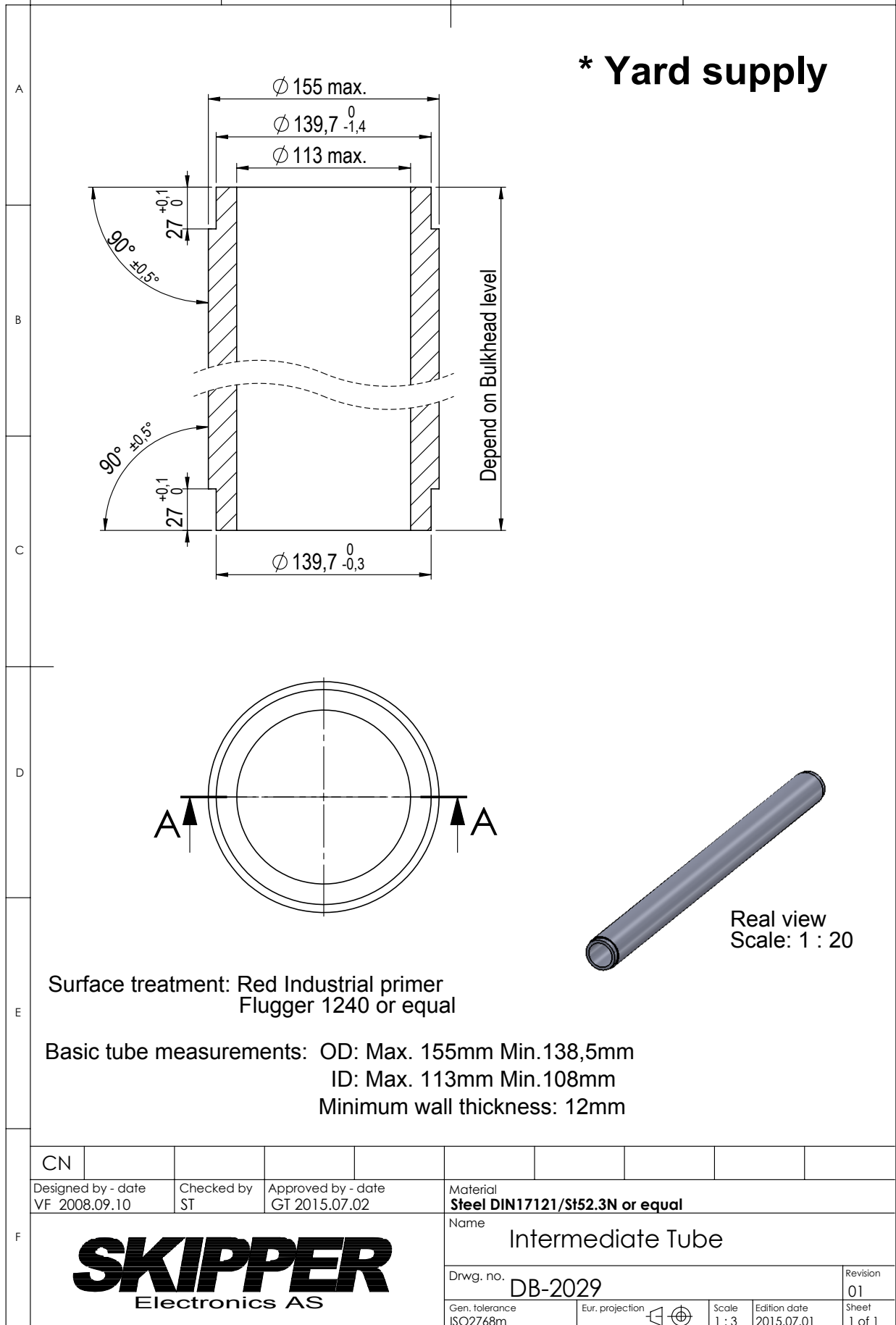

Surface treatment: Red Industrial primer
Flugger 1240 or equal

Basic tube measurements: OD: Max. 155mm Min. 138,5mm
ID: Max. 113mm Min. 108mm
Minimum wall thickness: 12mm

CN									
Designed by - date VF 2008.09.10	Checked by ST	Approved by - date GT 2015.07.02	Material Steel DIN17121/St52.3N or equal						
			Name Intermediate Tube						
			Drwg. no. DB-2029						Revision 01
			Gen. tolerance ISO2768m	Eur. projection 	Scale 1 : 3	Edition date 2015.07.01	Sheet 1 of 1		

4. Blanking plate

1		2	3		4
RevNo	Revision note			Date	Signature
					* Yard Supply

Adjust to Intermediate Tube dimension (DB-2029)

Material: Steel DIN17121/ST52.3N
 Thickness: Same as Tank Top
 Surface Treatment: Flugger 1240 Industriprimer. Colour: Red
 Gen. tolerance: ±3

Itemref	Quantity	Title/Name, designation, material, dimension etc			Article No./Reference	
Designed by V.Folgerø	Checked by A.Matre	Approved by - date VF- 2005.03.03	File name	Date 2004.10.19	Scale	
SKIPPER Electronics A/S			Blanking Plate			
			DB-2028-Rev-00	Edition	Sheet 1/1	

5. Welding the bottom flange

- When the position has been decided, a 170 mm hole is cut in the hull, and a 200 mm hole is cut in the bulkhead (tanktop).
- The bottom flange, Item (1) is welded into the hull. Standard welding practice, methods and procedures should be observed, but may vary. (See welding notes).

Attention:

The bottom flange is a part of the Sea Valve that is machined with high accuracy and it should be protected after mounting to avoid damage to the bottom flange surfaces. This to avoid leakage. If the valve is pre-mounted, be sure to protect the valve from being polluted by welding debris.

WELDING NOTES!

All bottom parts and flanges for welding are precisely machined parts. During welding of these parts to the ship's hull plates, careful attention must be paid to avoid construction strain on the bottom parts and flanges.

- Let parts cool down during welding.
- Over heating may change fit and form and result in non-conformity with intended sensor/transducer.
- Welding to thick hull steel plates will exert high stress on bottom parts and flanges.
- Especially care must be taken during welding of stainless steel flanges.
- Work must be performed by a qualified and certified welder.

Welding the Bottom Flange in Ship's Hull

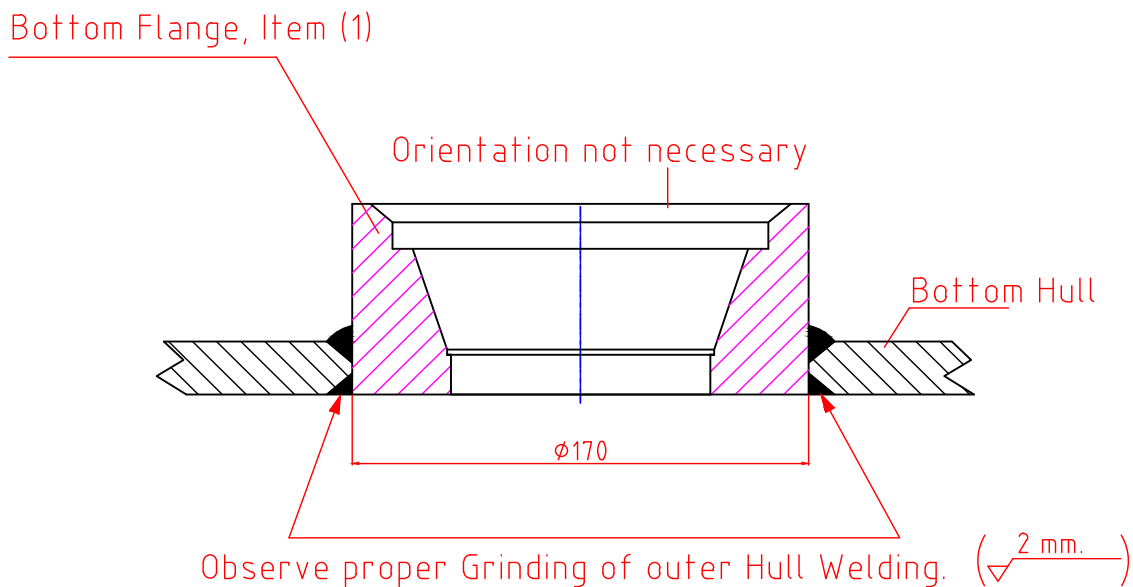

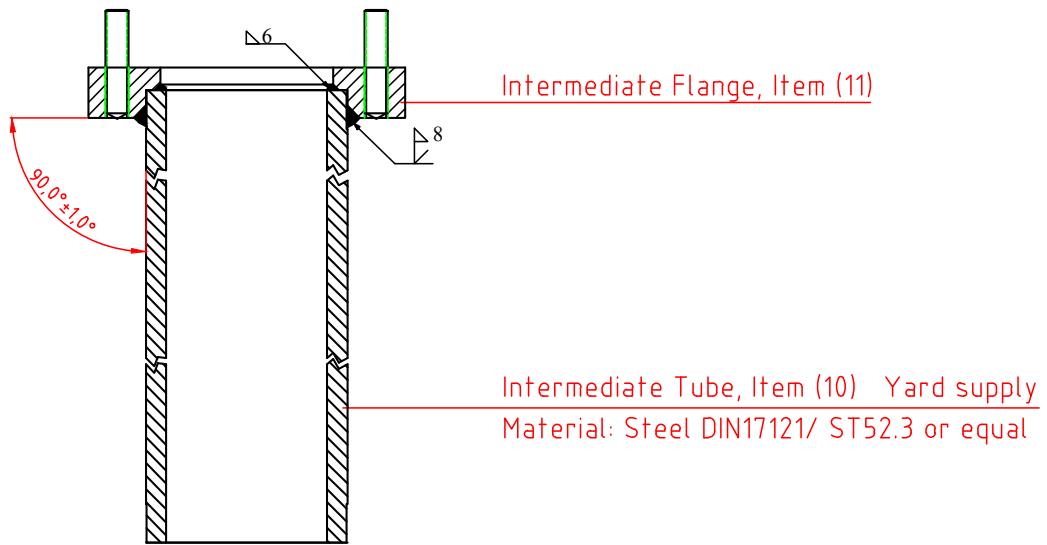

- Intermediate flange Item (11) is welded into intermediate tube Item (10). (*Yard supply). Standard welding practice, methods and procedures should be observed. (See welding notes).
- Blanking plate Item (9) (*Yard supply) is placed over the 200 mm hole in the bulkhead.
- Intermediate tube Item (10) is tread into the blanking plate Item (9) and through the 200 mm hole in the bulkhead.
- Standard welding practice, methods and procedures should be observed. (See welding notes).

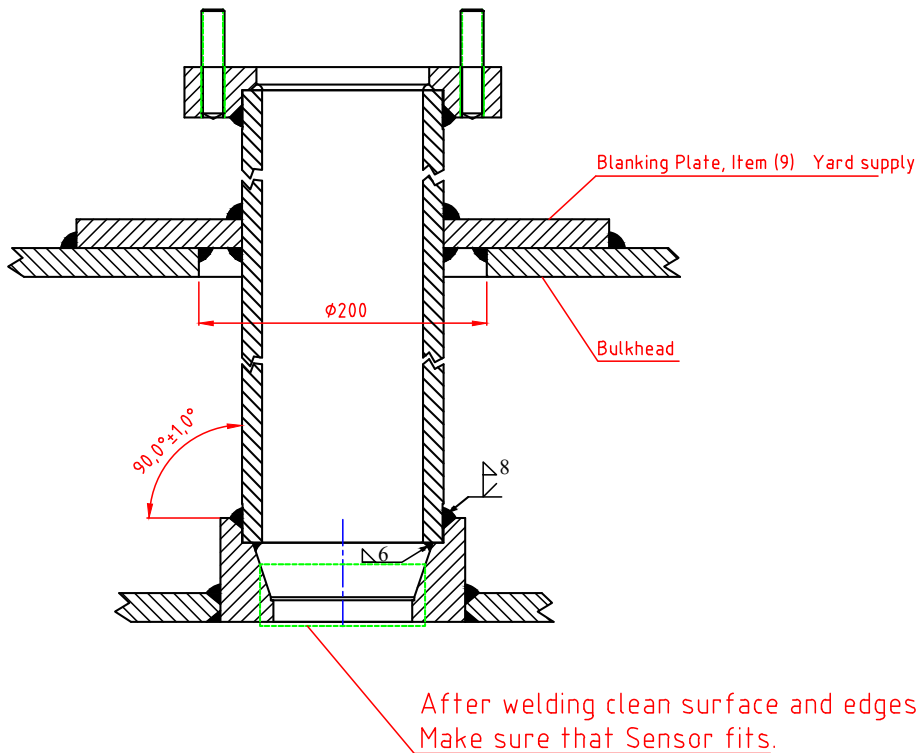

6. Sea Valve Assembly

Sea Valve Assembly (Orientation not necessary).

- Place a 1.5 mm Klingersil gasket, Item (23) on top of intermediate flange Item (11).
- Then place the valve element on top of the intermediate flange. The 16 mm nuts and washers should be mounted and tightened. (Align parts before tighten nuts).
- Place a 1.5 mm Klingersil gasket Item (23) on top of the valve element.
- Mount the intermediate element, Item (12) on top of the valve element.
- All 8 screws, nuts and washers should be mounted, and tightened. (Align parts before tighten nuts).

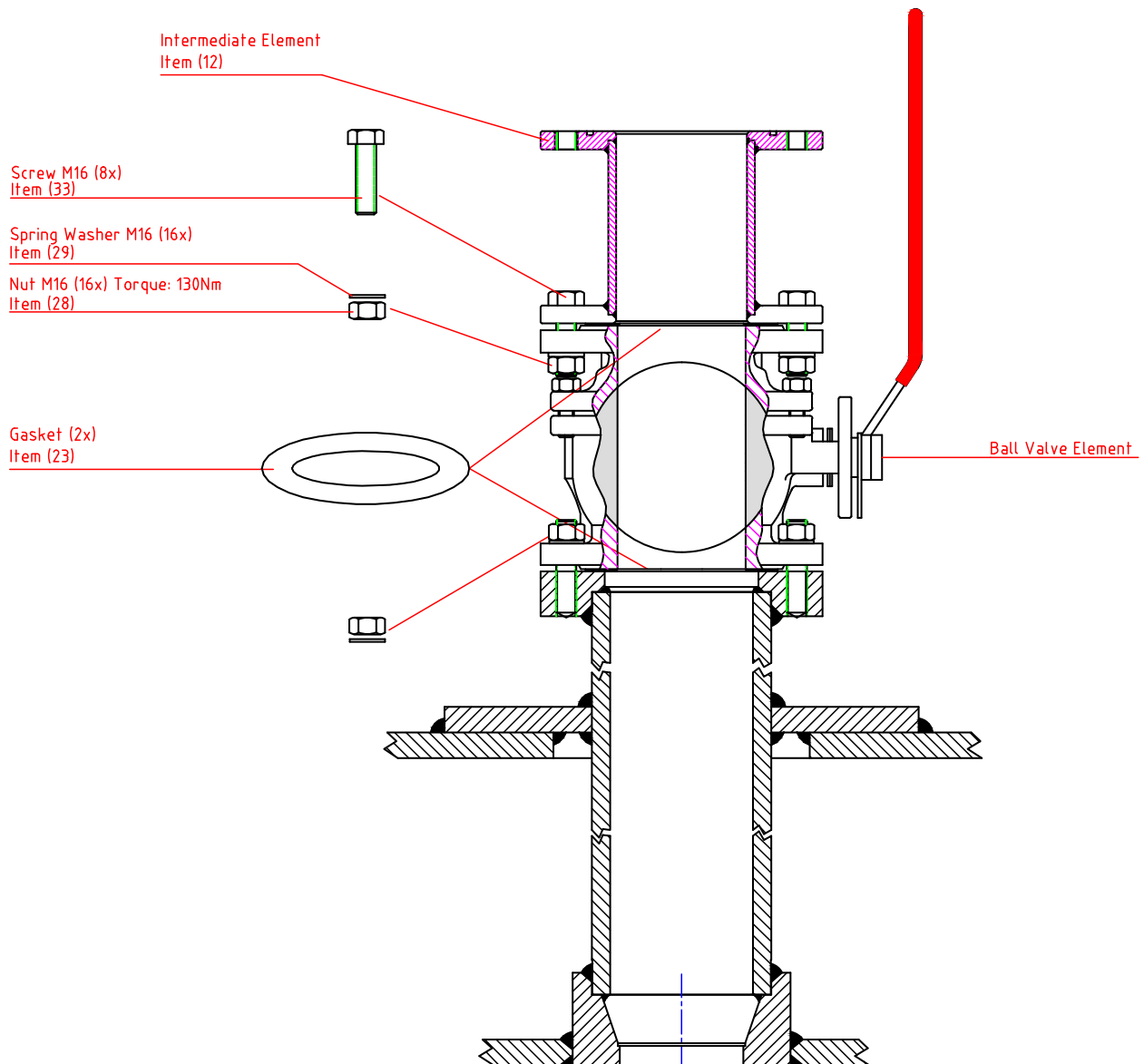

7. Assembling of first extension tube and sensor

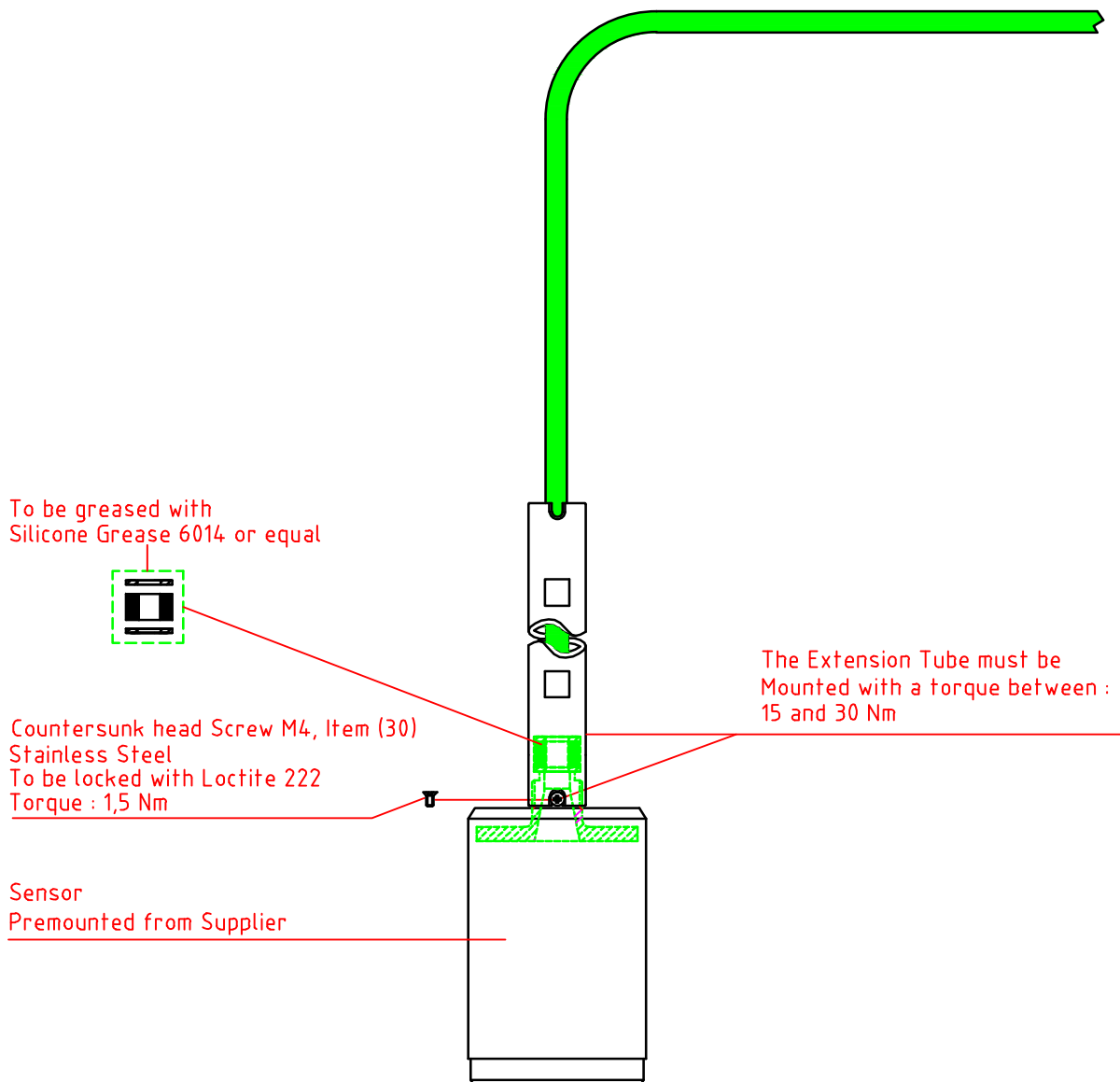

8. Sensor installation

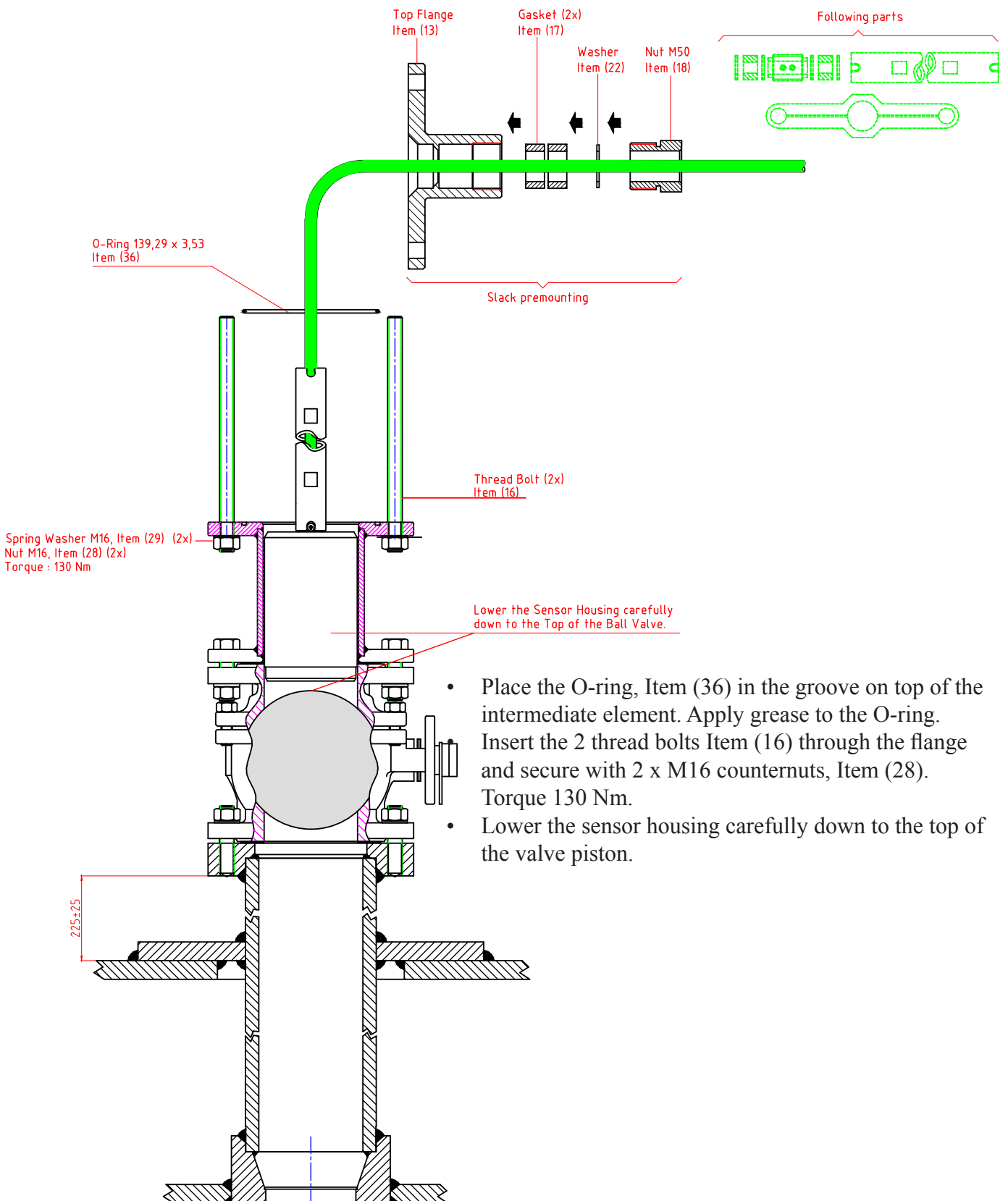

9. Clamp Unit mounting

Mount top flange Item (13). Secure with 8 each washers and nuts. Torque: 130 Nm.

Mount in following order:

- 2 x gasket, Item (17).
- Washer, Item (22).
- Nut M50, Item (18).
- 2 x M16 nuts, Item (28).
- Clamp unit, Item (15).
- 2 x M16 nuts, Item (28) with spring washer, Item (29).

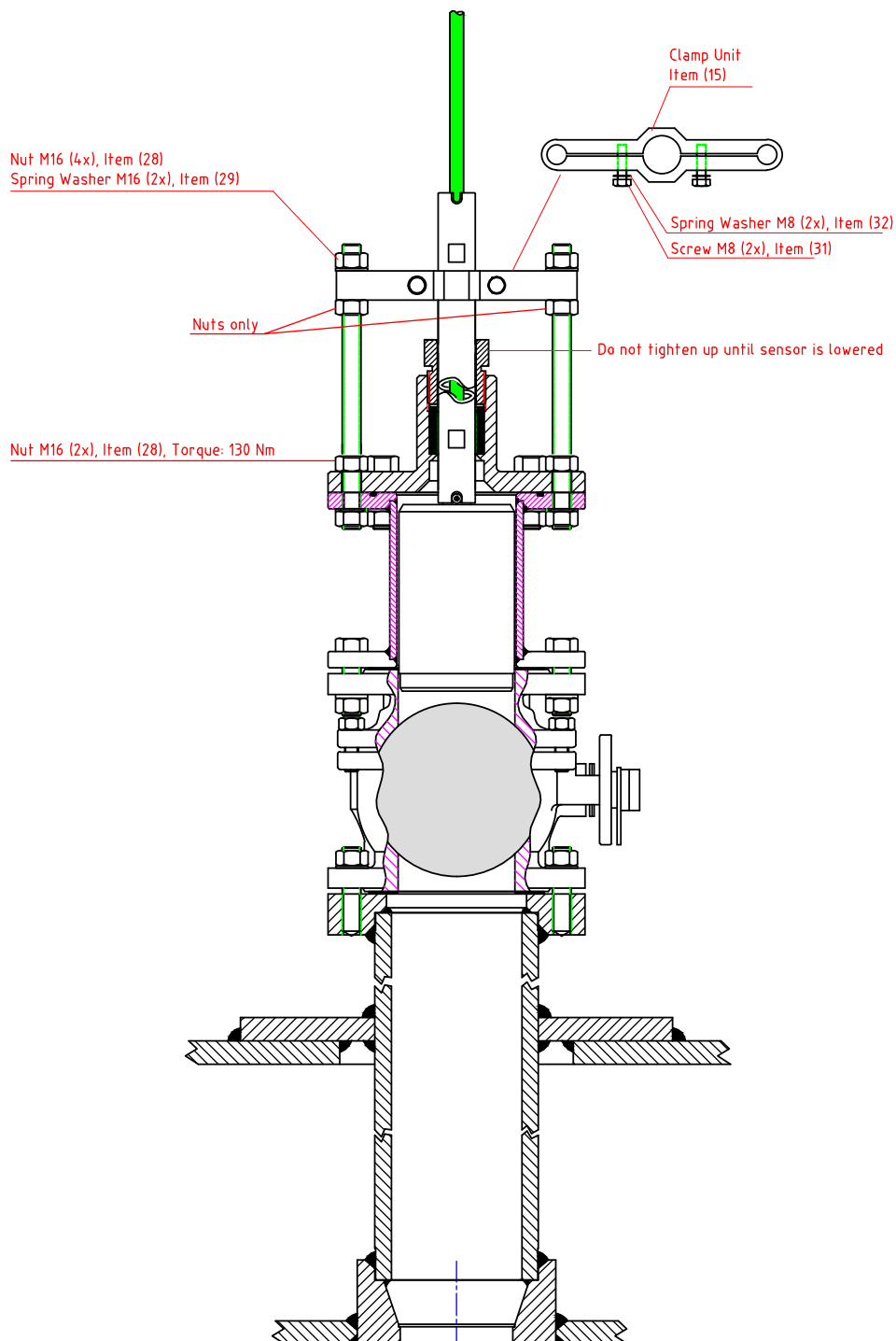

10. Extension tube mounting order

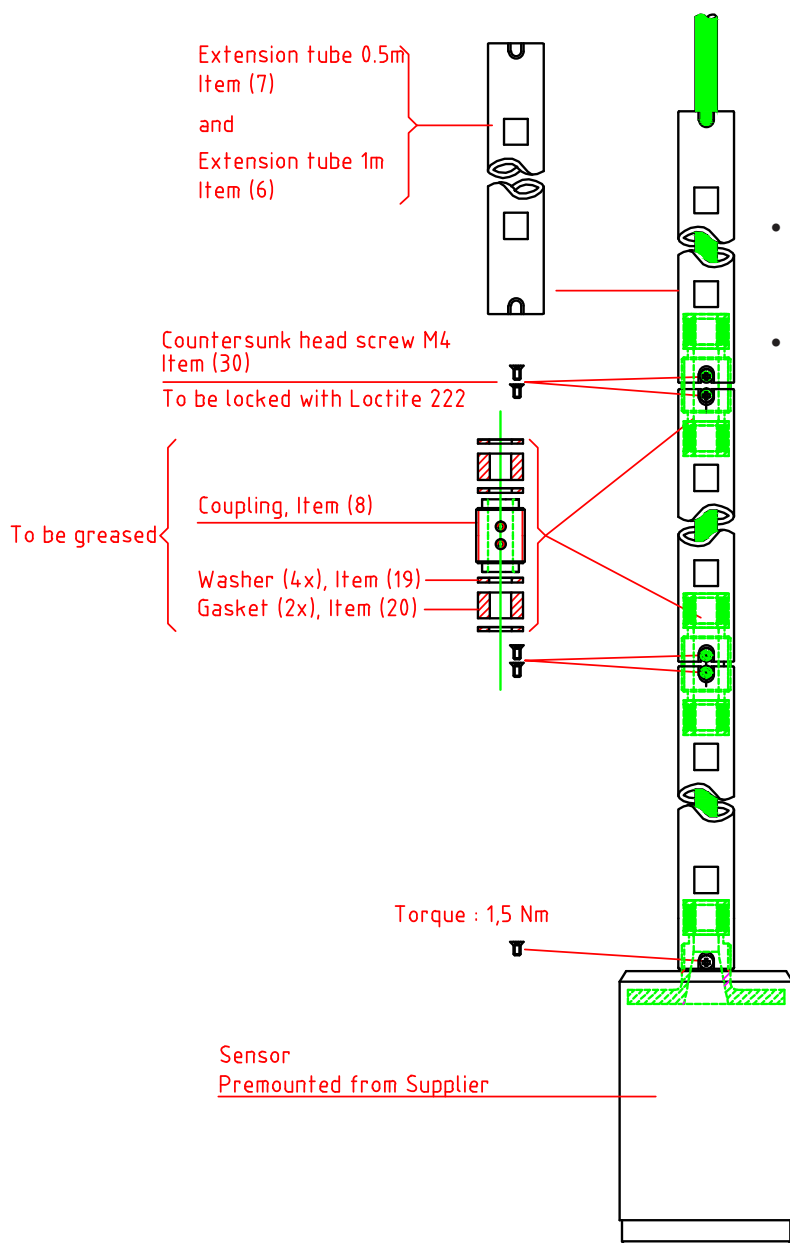

- The extension tubes and coupling must be mounted with a torque between 15 and 30 Nm.
- The countersunk head screw must be mounted with a torque 1.5 Nm.

- Open Sea Valve, lower sensor unit and first Extension Tube.
- Rotate the Extension Tube to align the sensor to point forward (ahead), (only needed for Speed Log).
- Use the flattened area on the Extension Tube to find correct direction. (See fig. 11 Final Assembly).
- Tighten up the 2 x screw M8 before mounting next Extension Tube.

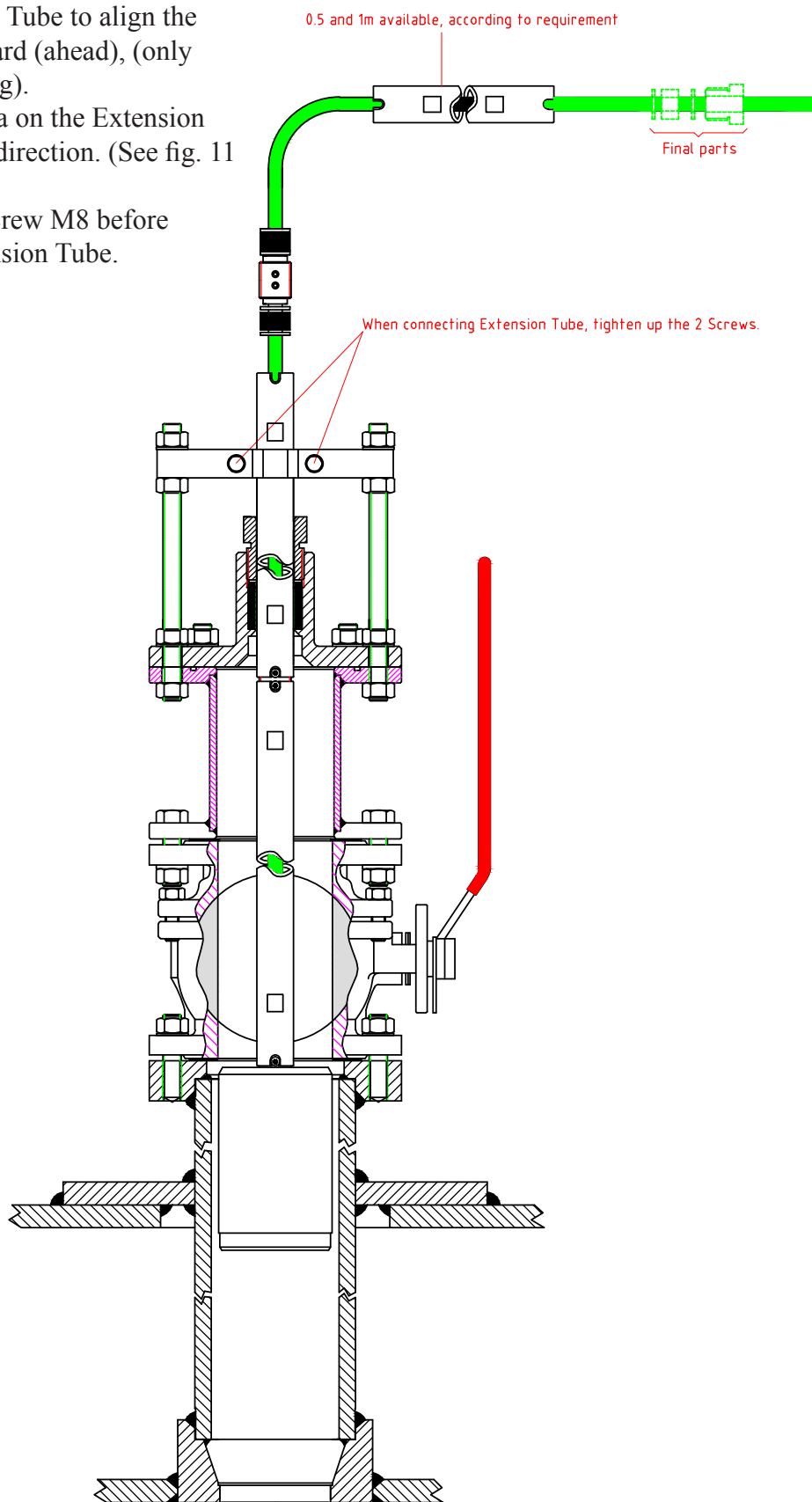

11. Final assembly

- After the ship is afloat, is it necessary to let the air out of the Sea Valve.
- Loosen the M50 nut, let the air out and tighten nut again.

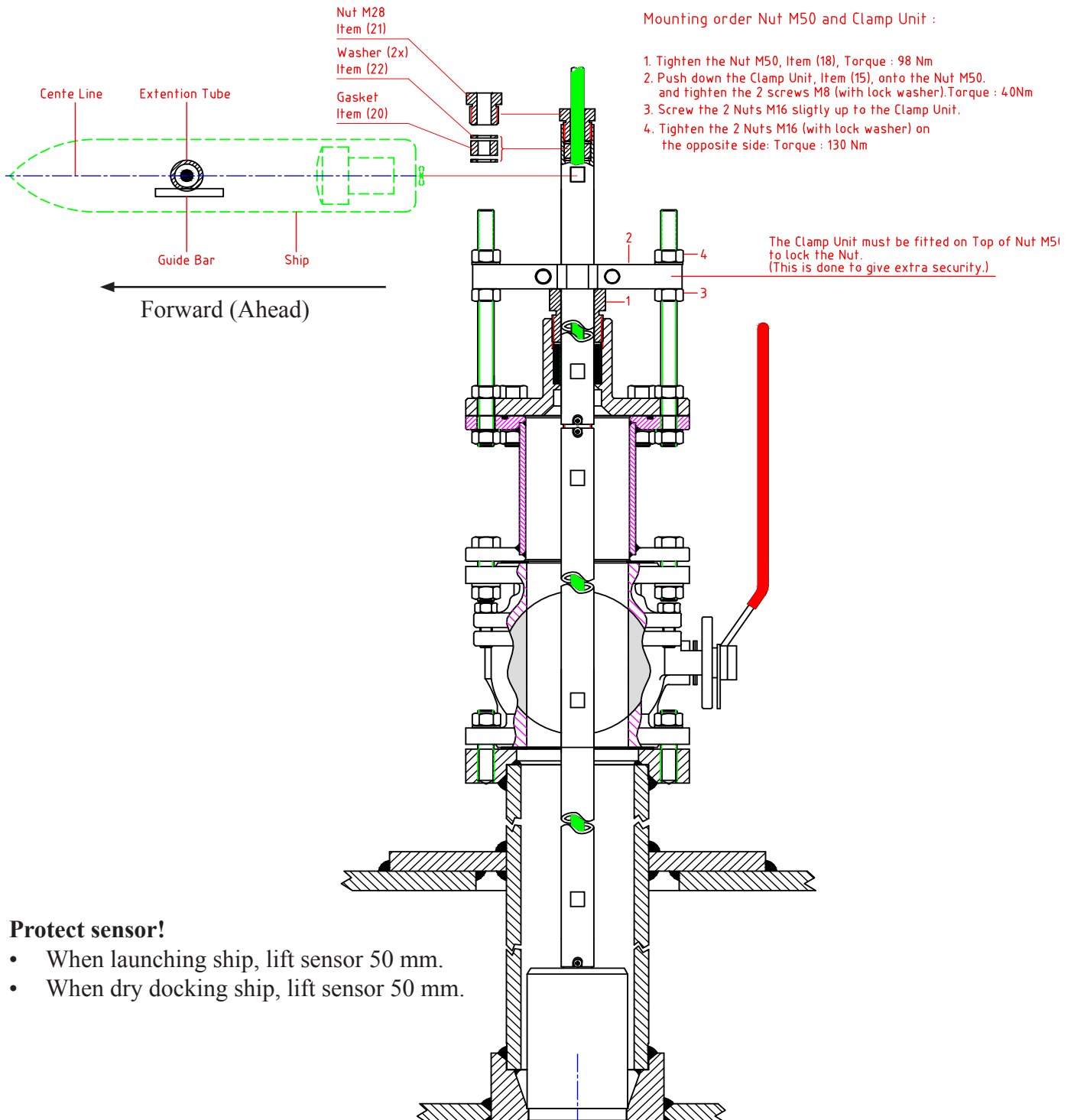

Protect sensor!

- When launching ship, lift sensor 50 mm.
- When dry docking ship, lift sensor 50 mm.

Check that the transducer/sensor housing, when fully inserted, is flush with the lower surface of the bottom flange.

12. Sensor removal

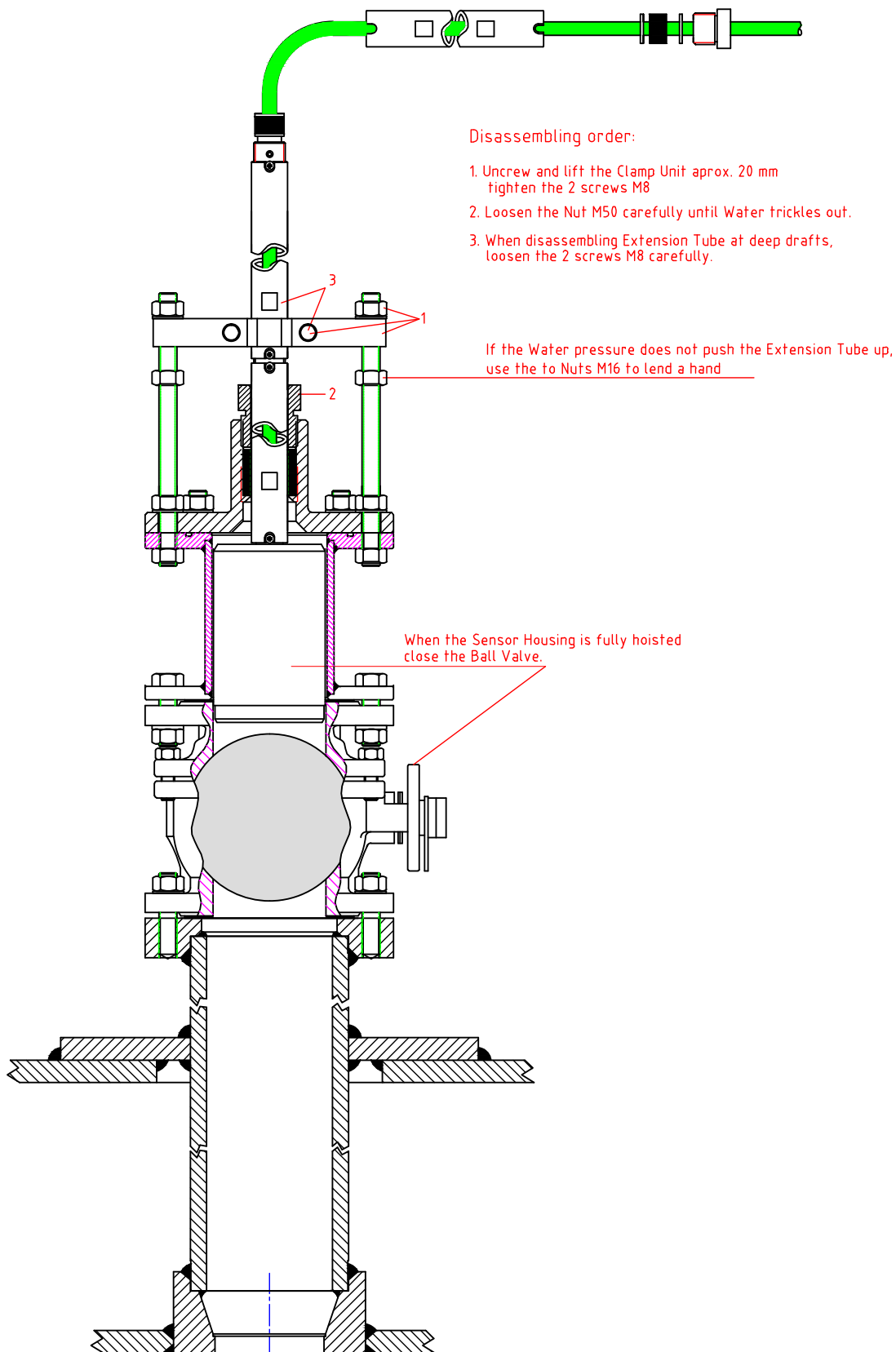

13. Re-installation

Same procedure as first-time mounting.

Mounting order Nut M50 and Clamp Unit :

1. Tighten the Nut M50, Item (18), Torque : 98 Nm
2. Push down the Clamp Unit, Item (15), onto the Nut M50. and tighten the 2 screws M8 (with lock washer). Torque : 40Nm
3. Screw the 2 Nuts M16 slightly up to the Clamp Unit.
4. Tighten the 2 Nuts M16 (with lock washer) on the opposite side: Torque : 130 Nm

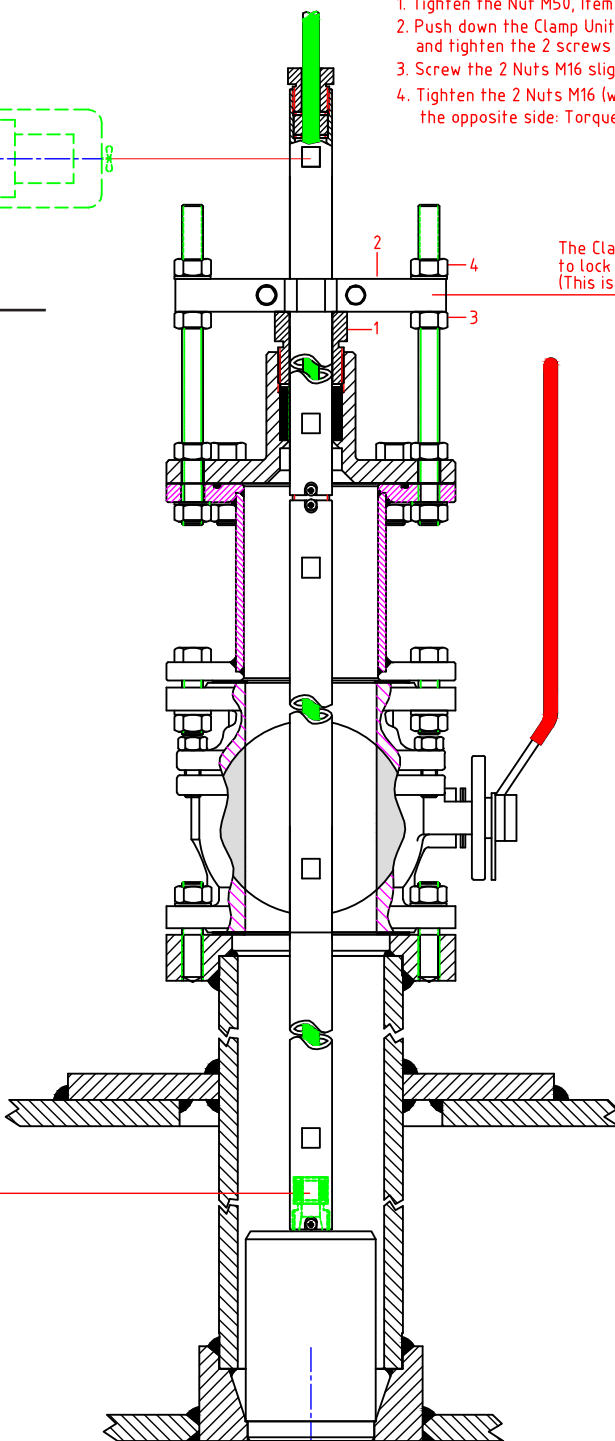
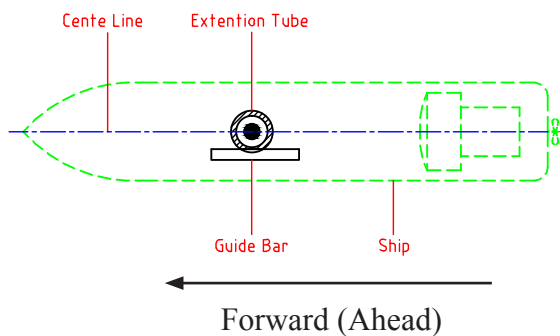

The Clamp Unit must be fitted on Top of Nut M5 to lock the Nut. (This is done to give extra security.)

To be greased with Silicone Grease 6014 or equal



14. DB-100 Sensors

All units premounted by Skipper Electronics

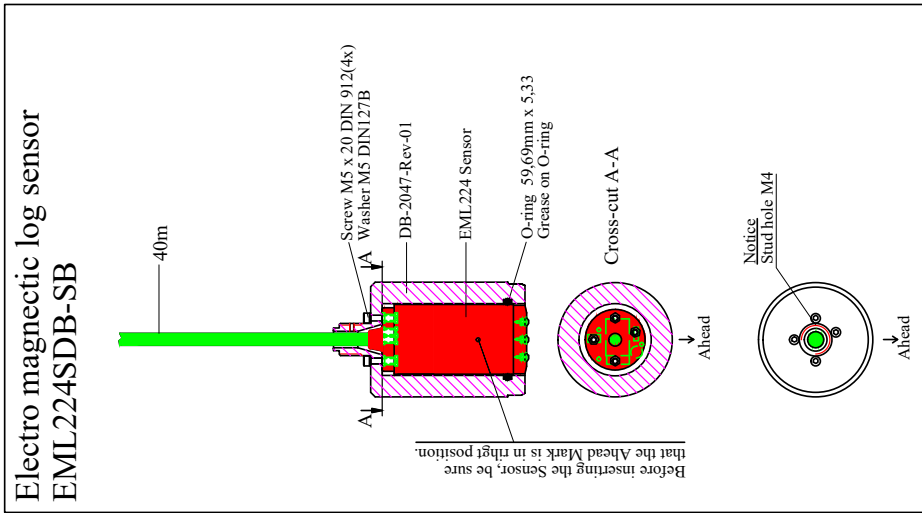
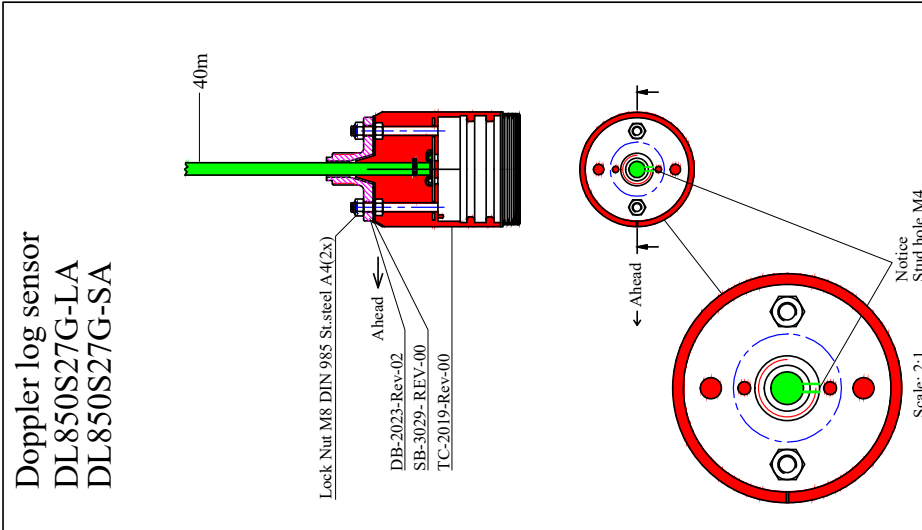
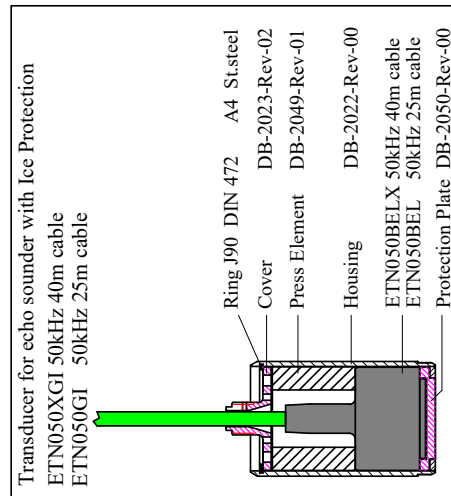
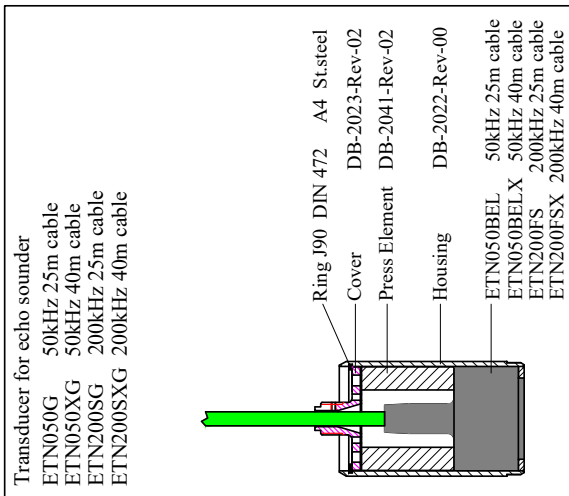

Itemref	Quantity	Title/Name, designation, material, dimension etc	Article No./Reference
Designed by A.Maire	Checked by VF	Approved by - date GT-2006/222	Date 30.11.2009
SKIPPER Electronics A/S		File name DB-100-Sensors	Scale 1/1
DB-2046-Rev-03		Edition	Sheet 1/1

Revision note: 8 Date: Signature: Checked

1 2 3 4 5 6 7 8

A B C D E F

15. 100 mm Double Bottom Ball Valve

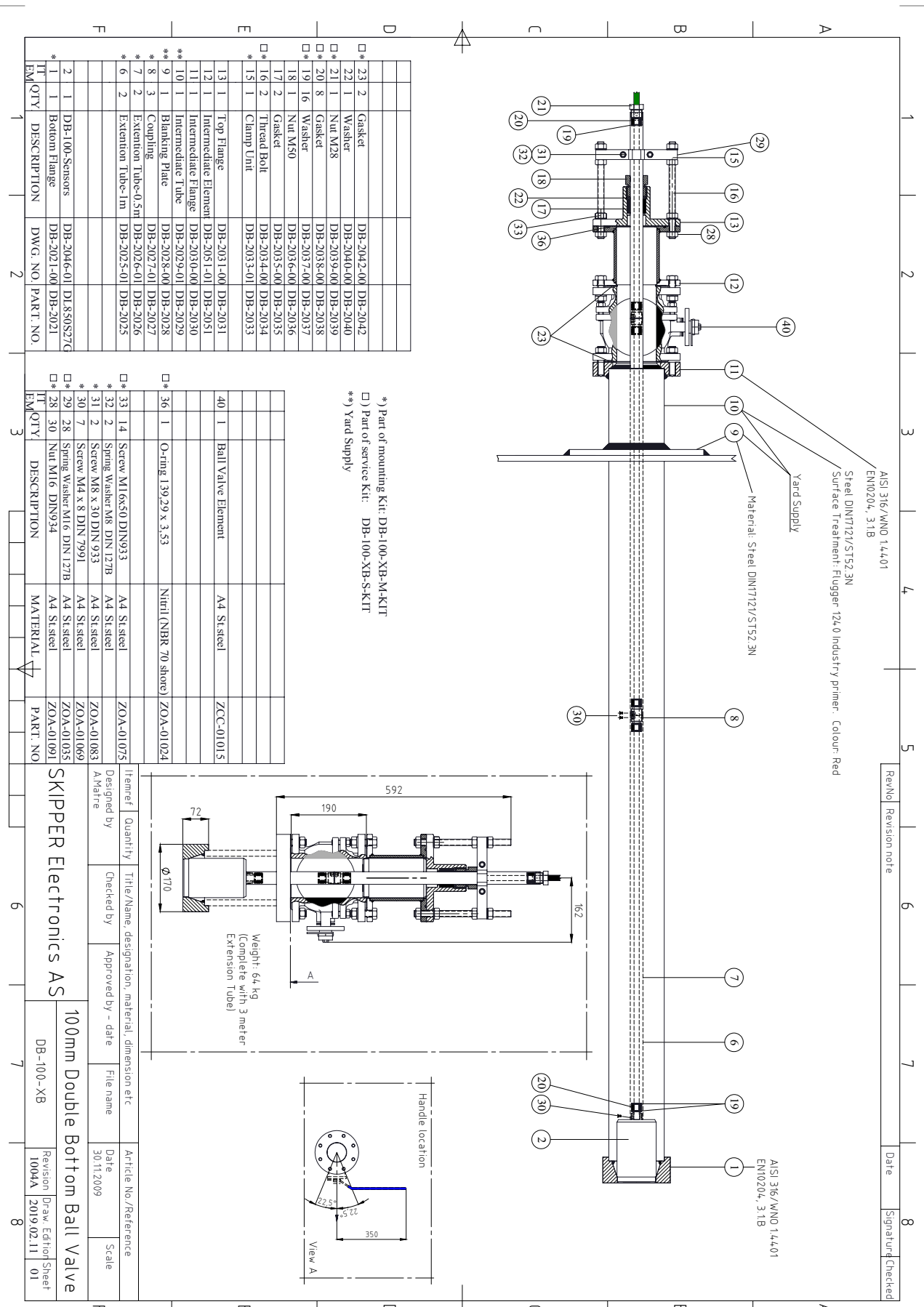

23	2	Gasket	DB-2042-00	DB-2042
22	1	Washer	DB-2040-00	DB-2040
21	1	Nut M28	DB-2039-00	DB-2039
20	8	Gasket	DB-2038-00	DB-2038
19	16	Washer	DB-2037-00	DB-2037
18	1	Nut M50	DB-2036-00	DB-2036
17	2	Gasket	DB-2035-00	DB-2035
16	2	Thread Bolt	DB-2034-00	DB-2034
15	1	Clamp Unit	DB-2033-01	DB-2033
13	1	Top Flange	DB-2031-00	DB-2031
12	1	Intermediate Element	DB-2051-01	DB-2051
11	1	Intermediate Flange	DB-2050-00	DB-2050
10	1	Intermediate Tube	DB-2029-01	DB-2029
** 9	1	Blanking Plate	DB-2028-00	DB-2028
** 8	3	Coupling	DB-2027-01	DB-2027
* 7	2	Extension Tube-0.5m	DB-2026-01	DB-2026
* 6	2	Extension Tube-1m	DB-2025-01	DB-2025
2	1	DB-100-Sensors	DB-2046-01	DI.830627G
* 1	1	Bottom Flange	DB-2021-00	DB-2021

40	1	Ball Valve Element	A4 St. steel	ZCC-01015
36	1	O-ring 1.39.29 x 3.53	Nitril (NBR 70 shore)	ZOA-01024
33	14	Screw M16x50 DIN933	A4 St. steel	ZOA-01075
* 32	2	Spring Washer M8 DIN 127B	A4 St. steel	ZOA-01083
* 31	2	Screw M8 x 30 DIN 933	A4 St. steel	ZOA-01083
* 30	7	Screw M4 x 8 DIN 7991	A4 St. steel	ZOA-01069
* 29	28	Spring Washer M16 DIN 127B	A4 St. steel	ZOA-01035
* 28	30	Nut M16 DIN934	A4 St. steel	ZOA-01091

*) Part of mounting Kit: DB-100-XB-M-KIT
 □) Part of service Kit: DB-100-XB-S-KIT
 **) Yard Supply

Item ref	Quantity	Title/Name, designation, material, dimension etc	Article No./Reference
Designed by			Date
Checked by			30.11.2009
Approved by - date			Scale
File name			

SKIPPER Electronics AS

100mm Double Bottom Ball Valve

DB-100-XB

Revision 1004A Draw: Editor Sheet 2019.02.11 01

RevNo	Revision note	Date	Signature/Checked
1			